



# Guidelines for the Design and Management of Bicycle Parking Facilities

DRAFT - MAY 2008

<b>1. INTRODUCTION</b>	<b>1</b>
1.1. BACKGROUND	
<b>2. DESIGN GUIDELINES FOR BICYCLE PARKING ON PROPERTY OUTSIDE OF THE PUBLIC RIGHT-OF-WAY</b>	<b>3</b>
2.1. BICYCLE PARKING DEFINITIONS	3
2.2. CRITERIA FOR GOOD QUALITY BICYCLE PARKING:	3
2.3. SHORT-TERM BICYCLE PARKING	4
2.3.1. Rack Design	
2.3.2. Covered Bicycle Parking	
2.3.3. Installation	
2.4. LONG-TERM BICYCLE PARKING	7
2.4.1. Bicycle Lockers	
2.4.2. Bicycle Cages	
2.4.3. Indoor Bicycle Parking (Parking Garage)	
2.4.4. Indoor Bicycle Parking (Bike Room)	
2.5. SHOWER / CHANGE FACILITIES	10
2.6. EMERGING TECHNOLOGIES AND INNOVATIONS	11
2.7. BICYCLE PARKING ISSUES BY DEVELOPMENT TYPE	11
2.7.1. High-Rise & Low-Rise Residential Uses	
2.7.2. Commercial, Industrial, Institutional Uses	
2.7.3. Uses with High Bicycle Parking Demand	
<b>3. SITE DESIGN STRATEGIES</b>	<b>15</b>
3.1. ACCESSIBILITY	15
3.2. STAIRWAYS	15
3.3. BICYCLE PATHS ON-SITE	15
3.4. DESIGNING FOR CONVENIENCE	16
3.5. SIGNAGE	16
3.6. SAFETY AND SECURITY	16
3.7. CREATING ATTRACTIVE BICYCLE PARKING	17

---

<b>4. BUILDING MANAGEMENT, OPERATIONS AND EMPLOYER-BASED STRATEGIES</b>	<b>19</b>
4.1 SHORT-TERM BICYCLE PARKING	19
4.2 LONG-TERM BICYCLE PARKING	19
4.2.1 Bicycle Lockers	
4.2.2 Bicycle Cages	
4.2.3 Indoor Bicycle Parking (Underground Parking Garage)	
4.2.4 Indoor Bicycle Parking (Bike Room)	
4.3 SECURITY AND FACILITY OPERATIONS	20
4.4 BUILDING ACCESS	21
4.5 INCENTIVES TO ENCOURAGE BICYCLE USE	21
<b>5. BICYCLE PARKING FACILITIES IN THE PUBLIC RIGHT-OF-WAY</b>	<b>23</b>
5.1 NEW DEVELOPMENTS PROGRAM	23
5.2 BICYCLE RACK PLACEMENT AND DESIGN	23
5.3 LONG-TERM PARKING	24
<b>6. POLICY CONTEXT</b>	<b>25</b>
6.1 CITY OF TORONTO OFFICIAL PLAN	25
6.2 CITY OF TORONTO BIKE PLAN	25
6.3 TORONTO GREEN DEVELOPMENT STANDARD 2008	25
6.4 CITY OF TORONTO ZONING BY-LAW PROJECT	26
6.5 VIBRANT STREETS GUIDELINES	27
6.6 NATIONAL AND INTERNATIONAL ENVIRONMENTAL STANDARDS AND CERTIFICATIONS	27
6.7 PROVINCIAL POLICIES	28
<b>7. CONCLUSION</b>	<b>29</b>
<b>8. APPENDIX A: CONCEPTUAL SITE PLAN</b>	<b>31</b>

---

9. APPENDIX B: RELEVANT POLICIES AND BY-LAWS.	33
10. APPENDIX C: BICYCLE PARKING BROCHURE	37



## 1. INTRODUCTION

Sustainable growth and development of a healthy and liveable Toronto, comes in part through a reduction in auto dependency and the support and further development of alternative modes of transportation. In keeping with the City of Toronto's growth management objectives, current City policies and implementation measures provide for the accommodation and growth of bicycle transportation through an increase in quality bicycle infrastructure. These Guidelines like those the City has approved for streetscape design, bicycle lanes, green parking lots, and drive-throughs support the effective implementation of high quality, well integrated, sustainable and attractive transportation infrastructure.

### 1.1 BACKGROUND

Guidelines for the Design and Management of Bicycle Parking Facilities are intended to improve the quality of bicycle parking that is secured through the development approval process. These Guidelines will provide planners, developers and property managers with information to support the design, construction and management of high quality bicycle parking facilities. In doing so, this Guide will be of assistance in the preparation of Transportation Demand Management (TDM) Plans (required for large developments) as well as serve as a tool for meeting higher standards such as those set by the Toronto Green Development Standard and other environmental design certifications. In addition to new developments, the Guidelines may also provide direction for existing buildings undergoing redesign or renovation.

Bicycle parking associated with new developments is normally provided on the development property, however, there may be instances where it is either not possible or desirable to accommodate all bicycle parking requirements on-site. Where bicycle parking is provided in the public right-of-way (on the sidewalk) the application of these bicycle parking guidelines will be conditioned by other regulations that apply to the public right-of-way (see Section 5).

Bicycles, as a mode of transportation, are emission-free, require less space on city streets and promote a healthy and active lifestyle. When used alone, or combined with

public transit, bicycles can provide the door-to-door convenience of private automobiles. Statistics show that in 2006 approximately 25,000 people in Toronto cycled to work<sup>1</sup>. This represented 1% of all commuters. This is a 0.2% increase from 2001 data that showed approximately 18,000 people in Toronto cycled to work.<sup>2</sup> In order to support a continued and greater increase in bicycle use for daily travel in Toronto, a combination of high-quality infrastructure, bicycle-friendly policy, education and promotion are required.



City of Toronto  
Post-and-Ring bicycle  
parking rack.

<sup>1</sup> Statistics Canada 2006 Census of Population

<sup>2</sup> Statistics Canada 2001 Census of Population



Bicycle parking at University of Toronto, St George Campus.

## 2. DESIGN GUIDELINES FOR BICYCLE PARKING ON PROPERTY OUTSIDE OF THE PUBLIC RIGHT-OF-WAY

Bicycle parking standards primarily deal with the quantity and type of facilities required. However, there are key design strategies that specifically address the quality of bicycle parking. The following guidelines will assist in the design and development of high quality bicycle parking facilities that will successfully meet the needs of cyclists and will work to encourage and support bicycle use.

### 2.1. BICYCLE PARKING DEFINITIONS

There are two categories of bicycle parking:

#### *Long-term bicycle parking*

- Also known as "bicycle parking space-occupant, or Type 1 bicycle parking".
- Includes bicycle racks in an enclosed, secured area with controlled access; or
- Individual, secure enclosures like bicycle lockers;

#### *Short-term bicycle parking*

- Also known as "bicycle parking space-visitor, or Type 2 bicycle parking"
- Includes bicycle racks in an easily accessible location;
- Available for public use;
- Sheltered or unsheltered;
- Does not protect bicycles from vandalism or theft attempts.

### 2.2. CRITERIA FOR GOOD QUALITY BICYCLE PARKING:

Although there are a wide variety of design strategies that can be used to implement good quality bicycle parking there are three main criteria that must be satisfied:

#### *Accessibility:*

- Close to building entrances
- At ground level or accessible from ground level (i.e. by ramps, elevators)
- No obstacles like stairs or steep slopes
- Separate, dedicated bicycle ramps into parking areas are desirable.
- Way-finding signage



*Safety and security:*

- Racks or lockers made from high quality materials and firmly secured to the ground, floor, or wall.
- Regularly monitored by security personnel
- Located in a well-lit area
- Short-term parking: located in a busy, public area to increase informal surveillance
- Long-term parking: located in a separate, access controlled area

*Convenience:*

- Easy to locate and access
- Easy to use
- Wherever possible, situated close to bicycle friendly routes

**2.3. SHORT-TERM BICYCLE PARKING**

Short-term or “visitor” bicycle parking is designed to be used for a few minutes up to a couple of hours. As a result, short-term parking should be easily accessible, racks should provide a secure point for locking up and it is best if racks are covered for weather protection.

**2.3.1. Rack Design**

There are several types of bicycle parking rack designs available for bicycle parking on property outside of the public right-of-way. The following key features of rack design determine their quality and suitability. (See Section 5 for details on bicycle rack installations on the sidewalk in the public right-of-way)

Design Options:

*Materials to look for:* galvanized steel; industrial grade materials.

*Materials to avoid:* wood; soft metals; untreated metals that will rust; and cast composites that are brittle and may crack under impact. For rack designs that have welded sections avoid materials like stainless steel that do not weld strongly as weak welded sections can easily be broken by thieves or vandals.

*Finishing:* Racks should have a smooth outer surface that will not damage or scratch bicycle frames.

EXAMPLES OF GOOD BICYCLE RACK DESIGN



Good bicycle rack design provides 2 or more contact points between the bicycle and rack. A tapping rail close to the ground would improve the rack on the right by making it more easily detectable for blind or visually impaired people.



These racks park multiple bicycles and allow cyclists to lock the bicycle frame and at least one wheel to the rack.



EXAMPLES OF BAD BICYCLE RACK DESIGN



Choosing inappropriate materials will compromise security. Welded sections of this stainless steel rack have been broken off by vandals or thieves.



Bikes park at 90° angles to this rack which only provides 1 point of contact per bike. If installed too close to an obstacle, like this rack, capacity is reduced to 1 or 2 bikes at most.



This "wheel bender" rack does not allow bicycle frames to be securely locked to the rack.

Good Design Features:

Good quality rack designs will provide the following:

*Two points of contact between the bicycle and the rack.*

- This allows both the frame and at least one wheel to be locked to the rack and supports the bicycle.

*Space-efficiency*

- Racks should allow a good number of bicycles to be parked in a small area while providing adequate space between bicycles to facilitate parking and locking.

*Detectability*

- A design that ensures the bicycle rack is easily detectable for partially sighted or blind people. For example, adding a tapping rail to span the bottom of an inverted U style rack will make it easier for visually impaired people to detect.

Poor Design Features:

The following qualities are examples of bad bicycle rack design:

- One point of contact between the bicycle and rack. It is usually not possible to lock both the frame and one wheel to a rack with only one contact point and the bicycle is more likely to fall over when parked.
- The rack only supports one bicycle wheel. These racks (commonly known as "wheel benders" for the damage they can cause to bicycle wheels) do not support the bicycle frame or allow the frame to be locked securely to the rack.



### 2.3.2. Covered Bicycle Parking

Sheltered racks provide an even higher quality of short term parking. Shelters offer weather protection and can help protect bicycles from accidental damage by providing greater separation from a sidewalk or parking area. Installing parking underneath awnings, overhangs or stairways can also provide good shelter and may avoid extra construction costs. An enclosed structure provides the best shelter however a simple covering will still help to protect bicycles and cyclists from rain and snow.



Covered bicycle parking at a Recreation Centre in Esquimalt, Victoria, BC. Photo Credit: John Luton.

### 2.3.3. Installation

**Anchoring:** All bicycle racks should be firmly secured to the ground or floor by bolting them to a hard surface or fixing them in concrete. Concrete is the preferred surface for maximum security although other surfaces may also be appropriate.

**Spacing:** Required minimum spacing between bicycles parked in a horizontal position is 0.6 metres by 1.8 metres with a vertical dimension of 1.9 metres. For bicycles parked in a vertical position the required spacing is 0.6 metres by 1.2 metres with a vertical dimension of 1.9 metres.

For bicycle racks that hold more than 2 bicycles the following guidelines include preferred aisle spacing and spacing between a linear series of racks in order to give bicycles adequate room to manoeuvre:

- 1) A minimum distance of 2.5 m. from any fire hydrant, entrance or loading area (based on the City of Toronto's post and ring bike stand placement guidelines)
- 2) For racks that hold multiple (>2) bicycles (based on rack manufacturers' installation guides):

- (a) *Distance between rack and wall, or other obstacle:*
  - i. Minimum **0.45 m** if bikes parked parallel to obstacle;
  - ii. Minimum **2.5 m** if bikes parked perpendicular to obstacle and rack has double-sided access;
  - iii. Minimum **0.6 m** if bikes parked perpendicular to obstacle and rack has single-sided access (side facing wall would not accommodate bicycles).



Covered, short-term bicycle parking in a surface parking lot in Ottawa, Ontario.

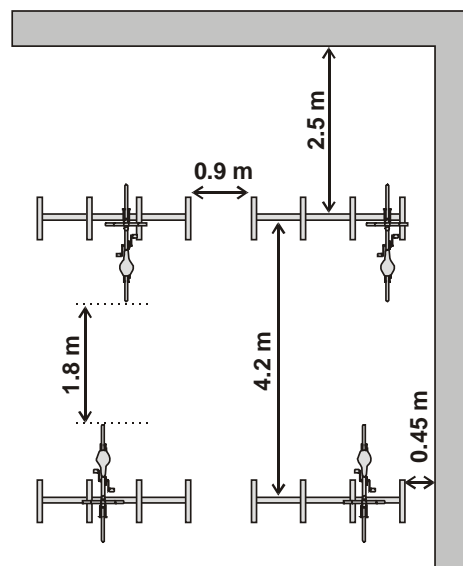

The above spacing is recommended for racks that park multiple bicycles to provide maximum parking capacity and allow bicycles to manoeuvre through the parking area.

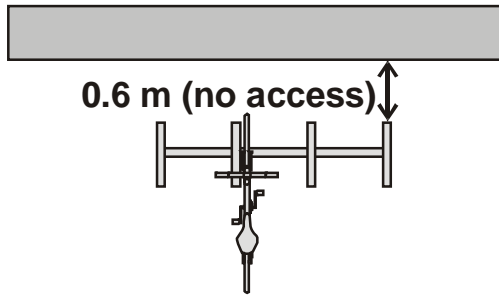

Space between an obstacle and a rack with single-sided access is necessary to allow bicycles to be parked and locked properly.

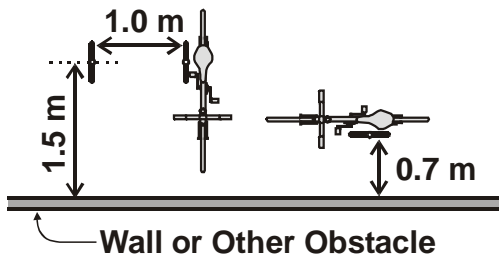

The orientation of bicycle racks determines the amount of spacing required. (See 3(a) and (b)(ii) on this page).

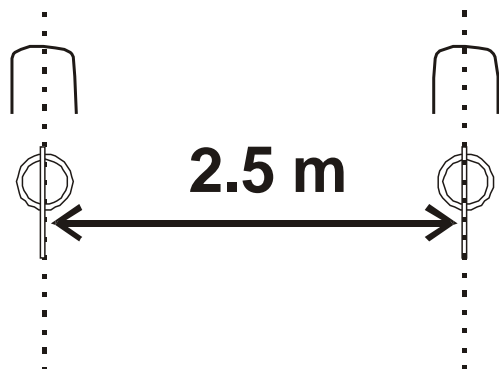

Recommended distance between racks installed in a parallel series (See 3(b)(i) on this page).

- (b) *Aisle width (space between bicycles):*
  - i. Preferred spacing: **1.8 m** For typical bike racks this leaves approximately 4.2 m between racks, however this spacing will differ depending on the design of the rack.
- (c) *Space between rack ends (for a linear series of racks placed end to end):*
  - i. **0.9m** for maximum parking capacity.

3) For racks that hold 2 bicycles (based on City of Toronto post-and-ring bike stand placement guidelines):

- (a) *Distance between rack and wall, curb or other obstacle:*
  - i. Minimum **1.5 m** for racks perpendicular to wall or other obstacle
  - ii. Minimum **0.7m** for racks parallel to wall, or other obstacle
- (b) *Distance between individual racks:*
  - i. Minimum **2.5 m** for racks parallel to wall, or other obstacle (3.5 m preferred in areas with high bicycle parking turnover).
  - ii. Minimum **1.0 m** for racks perpendicular to wall or other obstacle.

Decisions on the placement and spacing of all bicycle parking racks must include consideration for pedestrian movement. Bicycle racks should never be placed in a way that will interfere with pedestrian access to or from the bicycle parking facility or other pedestrian destinations on-site.

## 2.4 LONG-TERM BICYCLE PARKING

Long-term bicycle parking is intended for use over several hours or overnight. As a result, this parking must be designed to protect bicycles parked for longer periods of time.

### **2.4.1 Bicycle Lockers**

Bicycle lockers are individual storage units. They are weather-protected, enclosed and operated by a controlled access system that may use keys, swipe card (key fob) or



an electronic key pad located on a locker door. Some locker systems are set up for multiple users (i.e. coin operated or secured with personal locks). On average, two standard car parking spaces (of 5.6 m x 2.6 m each) can accommodate 10 individual bicycle locker spaces but this may differ depending on the locker model.

*Design Options:*

There are several locker designs available. Costs and quality of design may vary considerably. Security and durability are important criteria to consider when selecting a bicycle locker. Transparent panels are available on some models to allow surveillance of locker contents. Stackable models can double bicycle parking capacity on site. Integrated solar panels have been added to certain models for recharging electric bicycles. Options for customer access can vary from a simple, single-use key system to a multi-user system that allows secure access through smart card technology or electronic key pads.

*Installation:*

Bike Lockers require a level surface and clearance for locker doors. Concrete surfaces are preferred however requirements may vary for different locker models. Anchor bolts are used to fix lockers into place. Lockers should be located close to building entrances, or on the first level of a parking garage and within range of security surveillance. Bicycle Lockers are best placed away from sidewalks and areas with high pedestrian traffic. High quality, durable models that can withstand regular use, intense weather conditions and potential vandalism should be used.



Bicycle lockers in an underground parking garage (Ontario Institute for Studies in Education, University of Toronto).



Bicycle cage at Toronto Reference Library (Glass roof extends down from main building, wire mesh walls, restricted access through electronic key pad).

**2.4.2 Bicycle Cages**

Bicycle cages restrict access to bicycle parking racks through an electronic key pad, security pass card or a similar type of system. Good quality racks are installed inside the cage and bicycles are locked to these racks. See Section 2.3.3 for details on rack installation and spacing. Once inside the cage, an individual has access to all bicycles so it is important to closely monitor and enforce proper use of the cage.

*Design Options:*

For security purposes, small cages are best in order to limit the number of people with access to any one cage. For large developments with high demand for bicycle parking several small cages may be preferable. Walls must be made

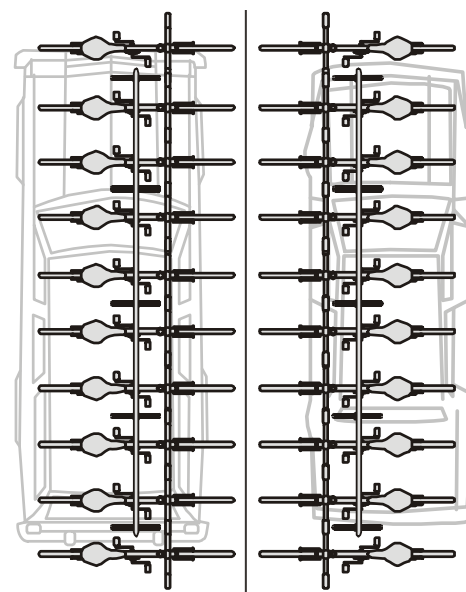

2 car parking spaces is approximately equal to 20 bicycle parking spaces.



Bicycle cage at South Riverdale Community Health Centre (perforated metal sheets used on lower half of walls). See inset for detail of upper section. Photo Credit: Paul Young; Artist: Jungle Ling.

of tight, strong mesh or perforated metal sheets to prevent attempts to cut through the cage or to reach through and trip the door latch or inside handle. A solid door may be required.

*Installation:*

Bicycle cages can be installed outside or inside a building or in a parking garage. Cage doors and roof must fit tightly against the cage walls. Both cage and bicycle racks inside must be firmly secured to the ground or floor.

*Cage Capacity:*

A single cage of 5.6 m x 5.4 m can accommodate approximately 20 bicycles. A cage of this size occupies the same area as two car parking spaces (one standard car parking space is 5.6 m x 2.6 m with a minimum 6 metre aisle width).

### 2.4.3 Indoor Bicycle Parking (Parking Garage)

Underground parking facilities offer many good options to accommodate high quality, long term bicycle parking. This can only qualify as long term parking if access to the parking garage is controlled or if the bicycle racks are otherwise secured (i.e. a bike cage, separate locked room or bicycle lockers). Providing more than one level of security (i.e. controlled access to garage + bicycle cages or lockers) will further improve the quality of the parking.

*Design Options:*

Bicycle parking should be located on the first level of a parking garage so that it is accessible from the ground level and interactions between bicycles and automobiles in the garage are minimized.

*Access Ramps:*

In order to easily accommodate two-way bicycle traffic, the preferred bicycle ramp width is 3.0m. The standard maximum gradient for automobile ramps is 15%. Depending on the placement of the ramp exit a 15% gradient may be too steep to be safely used by bicycles. The preferred ramp gradient for bicycle access is 6-7%. If there is adequate space a separate, dedicated bicycle ramp is preferred. Where possible, a dedicated bicycle ramp leading to a separated bicycle parking room will provide maximum safety and security for cyclists. (See Appendix A: Conceptual Design)



This parking garage provides a direct line to building security at the entrance for cyclists to request access. Only cyclists with security clearance can enter the garage.



### 2.4.4 Indoor Bicycle Parking (Bike Room)

Another option for long term bicycle parking is to use floor space within a building to create an indoor bicycle room. This room should be fitted with good quality bicycle racks that are securely fixed in place.

*Design Options:*

A dedicated, direct entrance into the bike room will improve security and convenience. Bike rooms should be at ground level or easily accessible by elevator and/or ramp. Locating the area within view of staff will improve security. For large developments where a large number of long-term bicycle parking spaces are required, providing several small bike parking rooms can improve security by giving fewer cyclists access to each room. The capacity of indoor parking rooms can be maximized by using two -tiered parking systems (see Section 2.6) and / or vertical parking racks where appropriate.

*Additional features:*

Reserving an area in the bike room for self-serve bicycle repair and maintenance will add an additional level of service to the facility. Features such as a bike stand, basic tools and/or an air pump will go beyond the basic requirements of a bike room to provide a high quality bicycle parking facility.

### 2.5 SHOWER / CHANGE FACILITIES

Shower and change facilities at non-residential developments can be a strong incentive to encourage bicycle use. These facilities are particularly important for employees or students who have a long commute or who are required to observe a professional dress code. The number of shower stalls available should reflect the amount of long-term bicycle parking on site. Although not required in the proposed standards, a minimum of one shower for smaller developments with 4 or less long-term bicycle parking spaces is preferred. The Toronto Green Development Standard 2008 sets the target for shower and change facilities to be provided at workplaces with one facility per gender for every 30 bicycle parking spaces. See Section 6.3 for more information on the Toronto Green Development Standard

*Design Options:*

Good design examples show showers and change rooms directly adjacent to secure bicycle parking facilities. Other



Intelliware Development Inc. (Toronto) employee bicycle parking is located in office lobby with a separate, bicycle entrance / exit. Photo credit: Lawrence Ludlow.



Employee indoor bicycle parking room at the Centre for Social Innovation (Toronto) Photo credit: Yvonne Bambrick.



Providing a bicycle stand and an area for minor bicycle maintenance is an easy way to add a valuable level of service to a bicycle parking room.

possibilities include arrangements to share other shower facilities on-site (i.e. in a building's fitness centre). These arrangements are appropriate provided that the shower facility is of adequate size to accommodate the expected amount of bicycle commuters at peak travel times and is in close proximity to the long-term bicycle parking. Personal lockers for clothing and equipment are an indispensable feature of change facilities. To provide a high quality change facility, the number of personal lockers would equal the number of long-term bicycle parking spaces on site.

## **2.6 EMERGING TECHNOLOGIES AND INNOVATIONS**

As bicycle use becomes more prevalent in urban centres the issue of providing good quality bicycle parking is becoming more important. With an increased demand for bicycle infrastructure new innovations and innovative uses of existing technologies continue to emerge.

*Examples include:*

- Bicycle parking stations – indoor bicycle parking facilities providing valet parking, bicycle repairs, bike rental, retail and bike sharing.
- Two and three-tiered bicycle racks to increase parking capacity without increasing floor space
- Bicycle lockers custom fitted with solar panels to recharge electric bicycles
- Bicycle sharing – bicycle loaning system provides bicycles and reserved bicycle parking for employees or residents

## **2.7 BICYCLE PARKING ISSUES BY DEVELOPMENT TYPE**

Specific bicycle parking requirements will differ depending on the type of development.

### **2.7.1 High-Rise & Low-Rise Residential Uses**

Multi-unit residential buildings require secure, long-term bicycle parking for residents in addition to a smaller amount of short-term visitor bicycle parking. Long-term parking should be easily accessible to encourage regular bicycle use while protecting residents' property (from both visitors and other residents in the building).



Mc Donald's Cycle Centre, Chicago, IL  
Two-tiered bicycle racks with manoeuvrable upper level increase capacity with safe and easy parking.



For condominiums, where separate dwelling units are privately owned, long-term bicycle parking infrastructure is best designed as a commonly owned feature of the development. Long-term bicycle parking would then be the responsibility of building management which would ensure high standards for management and maintenance of the facility.

### 2.7.2 Commercial, Industrial, Institutional Uses

When compared with residential uses, commercial developments often require a higher percentage of short term bicycle parking for customers and clients combined with secure, long term bicycle parking and shower facilities for employees. Covered, outdoor parking, close to building entrances offers customers and clients an important service, raising the profile of active transportation and meeting a growing demand in areas where surface parking for motor vehicles is scarce and traffic congestion is a concern.

### 2.7.3 Uses with High Bicycle Parking Demand

Some developments have the potential to generate a higher than average demand for bicycle parking.

*Examples include:*

- Schools – elementary, high schools, colleges and universities - Many students do not drive or do not own a personal motor vehicle.
- Hospitals, large factories and major transit hubs are destinations for large numbers of visitors, customers and employees who may require access to the site at all hours for shift work, late night travel schedules or emergencies.
- Places of assembly – stadiums, community centres or concert halls – can receive a very large number of short-term visitors during special events. These locations can create a high demand for secure bicycle parking.
- Places of worship like places of assembly, receive a considerable number of visitors at one time thereby increasing the demand for secure bicycle parking.



Employee Bike Share (yellow bikes) at the Centre for Social Innovation (Toronto) Photo credit: Yvonne Bambrick.



Bicycle Parking at Robarts Library, University of Toronto. The University's St George Campus has bicycle parking near the entranceways of most of its major buildings.

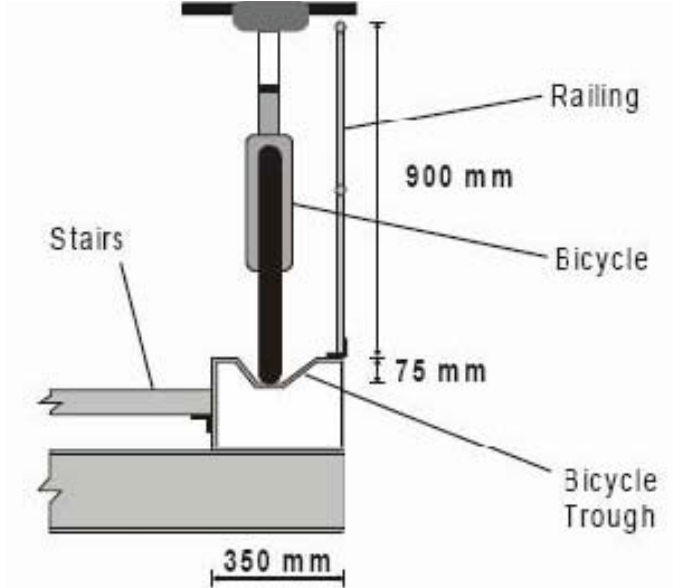

Design Guidelines for bicycle ramps on stairs from the City of Hamilton's Design Guidelines for Bikeways. Dec 1999.



Channel for bicycle wheel in concrete staircase at McDonald's Cycle Centre, Chicago.

### 3. SITE DESIGN STRATEGIES

In addition to the design of bicycle parking facilities, there are broader features that can be included in site design to create a bicycle friendly destination and increase usage of bicycle parking facilities.

#### 3.1. ACCESSIBILITY

Accessibility is one of the three basic requirements of good bicycle parking. Design strategies to enhance accessibility range from simple details like providing level access to outdoor bicycle racks from a road or driveway, to more complicated designs such as a separate, access controlled, dedicated bicycle ramp into an underground bicycle parking facility.

It is equally important to ensure that bicycle parking infrastructure is placed in such a way as it does not conflict with access to the site by other modes. Pedestrian access must not be hindered by bicycle racks, including pedestrians who are visually impaired or use mobility aids such as walkers, scooters, or wheelchairs. Bicycle racks should also be located in areas that will help to minimize interactions between automobiles and bicycles on-site. Larger infrastructure, such as bicycle lockers or cages can create blind spots and block lines of sight and should be installed in such a way as to mitigate these concerns.

#### 3.2 STAIRWAYS

Where possible, a site plan that includes stairways should also include an alternative, level access route for bicycles. If it is not possible to provide an alternative access, a ramp or a small channel for bicycle wheels on the edge of a stairway should be provided. This will prevent cyclists from having to carry bicycles up and down stairs. Stairs are not accessible for bicycles and stairway ramps should be used as a last resort.

#### 3.3 BICYCLE PATHS ON-SITE

For larger developments bicycle travel on-site may be an important consideration. In this case, dedicated bicycle paths, or markings indicating shared use could be implemented to accommodate cyclists crossing large parking lots or otherwise traveling on-site. These dedicated paths should be unobstructed and extend to the edge



of the property in two or more different directions. The minimum recommended width for a separated, marked bicycle path (two directions of travel) is 1.8 metres.

### 3.4 DESIGNING FOR CONVENIENCE

Installing short-term bicycle parking in a convenient location and close to building entrances will help to prevent unwanted parking against trees, wheelchair ramps, utility poles or railings. Buildings with more than one entrance should consider providing bicycle parking close to each entrance and particularly near entrances that are accessible via smaller streets or streets included in the City's bikeway network. Whenever possible, indoor parking facilities should allow 24-hour secure access.

### 3.5 SIGNAGE

Clear, simple signage will help cyclists locate bicycle parking and indicate to pedestrians and motorists that they should expect bicycle traffic on site. Integrated, high-quality and simple signage such as well placed symbols and directional arrows can be very effective.

### 3.6 SAFETY AND SECURITY

Bicycle parking facility design should maximize safety and security to both cyclists and their property. There are a number of strategies that can be used to accomplish this however the type and number of strategies used will depend on the particular facility.

*Examples include:*

- Installing security cameras in bicycle parking areas;
- Locating bicycle parking close to building entrances;
- Installing bright lights and/or convex mirrors to minimize blind spots and dark corners;
- Locating bicycle parking within view of parking lot attendants, building security, or in a busy area close to other public amenities;
- Dedicated (cyclist-only) entrances with limited access to indoor parking facilities and outdoor bike cages (i.e. security card access or non-duplicable keys)
- Installing a "panic button" in bicycle parking areas that would provide a direct line to security in the event of an emergency



Bicycle ramps on stairway (Riverdale Park, Toronto).



Directional signage for a bicycle station, Chicago, IL.



### **3.7 CREATING ATTRACTIVE BICYCLE PARKING**

Outdoor bicycle parking, whether it is short term or long term, can be an attractive part of site design. Bicycle parking racks or other systems can be designed and configured to coordinate with and complement site design, street furniture or other amenities on site. Bicycle racks can be custom built to suit specific needs and can double as public art thereby adding an eye-catching and creative feature to a building's exterior. However, any bicycle parking infrastructure that is installed on the public right-of-way (on the sidewalk) is subject to City guidelines and requirements (See Section 5 for more details).



Bicycle Rack Sculptures in Toronto's Parkdale neighbourhood function both as parking stands and as public art.



Locating bicycle parking next to a parking attendant's booth will facilitate surveillance and improve security.

## 4. BUILDING MANAGEMENT, OPERATIONS AND EMPLOYER-BASED STRATEGIES

In addition to good quality bicycle parking infrastructure, there are a number of operational strategies and incentives that will ensure successful use of the facilities provided.

### 4.1 SHORT-TERM BICYCLE PARKING

Well managed, short-term bicycle parking areas that are in good condition and appear clean and well cared for will be more secure. This can be accomplished by:

- Removing abandoned and derelict bicycles: Developing a system of tagging bicycles 1 week before removal will warn cyclists and will help distinguish abandoned bicycles from ones that are in use.
- Keeping the area free from garbage
- Clearing snow and other dirt / debris.
- Regular security monitoring to discourage theft, vandalism
- Repairing or replacing damaged racks
- Where appropriate, reserved parking for bicycle couriers in convenient locations can provide a valuable additional feature to short-term parking facilities.

### 4.2 LONG-TERM BICYCLE PARKING

#### 4.2.1 Bicycle Lockers

Providing bicycle lockers for the long-term parking needs of employees or building residents requires some basic management practices including:

- Monitoring locker use - Master keys or similar systems can allow access to the lockers;
- Maintenance - repair and replacement of damaged or malfunctioning parts. Depending on the quality of the lockers used, maintenance requirements can be minimal;
- Removing snow from the front of locker doors;
- Removing garbage and other debris from locker area.



#### 4.2.2 Bicycle Cages

A simple registration system can aid in the regulation and monitoring of users. Security pass card systems can be used and employee access cards can be programmed to allow access to a bicycle cage. Non-duplicable keys can be issued to building residents. As with all bike parking options, the bike cage should be under regular security surveillance.

#### 4.2.3 Indoor Bicycle Parking (Underground Parking Garage)

Automatic access control mechanisms on parking garages must be able to accommodate bicycles. Security card or key access can be used for both automobiles and bicycles. There are often additional detectors used in conjunction with security access devices to open gates or garage doors. If bicycles do not activate these detectors other options will need to be considered. In this instance, providing a direct line to building security at the garage entrance is one option that would allow cyclists to request entry.

#### 4.2.4 Indoor Bicycle Parking (Bike Room)

Bike rooms should be reserved for bicycle parking purposes only. Signage and enforcement of this will prevent misuse. Routine maintenance and cleaning will encourage use. Regular security surveillance and restricted access is required.

### 4.3 SECURITY AND FACILITY OPERATIONS

- Bike parking areas should be reserved for use by bikes only. Regular monitoring is required for signs of damage to bicycles or racks and signs of misuse such as storing items other than bicycles or extra auto parking.
- Bike parking areas should be under surveillance by security personnel through monitored security cameras and periodic foot patrols. Cyclists should be encouraged to report any vandalism or security concerns.
- Damage to bicycle racks should be repaired in a timely fashion and any derelict or abandoned bikes are removed so as not to prevent or discourage continued use of the racks.
- Policies to ensure prompt and regular snow removal, cleaning and garbage removal from bicycle parking areas should be adhered to. Aiming at a maximum



An electronic key pad is one option for a bicycle cage. Periodically resetting an access code will further improve security. Photo credit: John Luton.



A staff bicycle parking room at East York Civic Centre provides convenient indoor parking at-grade and allows access to cyclists only.



Bicycle parking in a retail development in the east waterfront neighbourhood has been designed to accommodate and encourage customers who wish to do their shopping by bicycle.

12 hour period (following snowfall) for snow removal will encourage and facilitate daily use of bicycles in all seasons.

#### **4.4 BUILDING ACCESS**

- For indoor parking a separate, dedicated entrance should be provided for cyclists. A secure entrance with key or security card access that is regularly monitored is best.
- Where there is no better access available for cyclists, bicycles should be accommodated on elevators.

#### **4.5 INCENTIVES TO ENCOURAGE BICYCLE USE**

- Economic incentives are often the most effective means of encouraging a change in routine.
- Parking Cash Out: In buildings where tenants, employees or other users are offered subsidized parking, cyclists could be provided with the cash equivalent since they do not use a car parking space. This could take the form of a travel allowance to be used for the purchase of a bicycle or cycling related gear.
- Business travel reimbursements: Employers who reimburse automobile mileage for business trips could reimburse bicycle mileage when cycling is comparable in speed to driving.
- Reward incentives: Providing cyclists with end of year gift certificates to bike shops. In exchange for publicity, some bike manufacturers have been known to donate bicycles or provide them at low cost.
- Hosting cycling-themed functions for employees, company teams for charity rides or bicycle races.



City of Toronto staff installing post-and-ring bicycle parking in the public right-of-way.

## 5. BICYCLE PARKING FACILITIES IN THE PUBLIC RIGHT-OF-WAY

Bicycle parking required by the Zoning by-law is normally provided on-site on private property. However, there are some instances where required bicycle parking may better be provided in the public right-of-way (on the sidewalk). In these instances there is either inadequate space on private property (which is often the case in dense, urban locations), or the public right-of-way is a more desirable location (provides a higher level of accessibility, security and convenience).

Any bicycle parking (whether required by the zoning by-law or not) that is located in the public right-of-way must comply with City standards and guidelines for all street furniture and must be installed by City staff.

### 5.1 NEW DEVELOPMENTS PROGRAM

If a developer is unable to satisfy the by-law requirements for short-term bicycle parking by installing facilities on the property, the City may allow bicycle racks to be placed within the public right-of-way. The amount, general location and arrangement of such facilities will be determined through the development approval process, in accordance with the relevant by-laws and guidelines. Transportation Services will provide and install post-and-ring bike racks, at the developer's expense. Payment of the required fee becomes one of the conditions of obtaining the appropriate landscaping or construction permit. The fee is currently \$200 per post, and should be submitted, along with a site drawing, to Transportation Services Pedestrian and Cycling Infrastructure Unit. More information can be obtained by calling 416-392-9253.

### 5.2 BICYCLE RACK PLACEMENT AND DESIGN

The placement and design of all street furniture in the public right-of-way is conditioned by a number of existing City by-laws, guidelines and contractual agreements. Any bicycle racks that are to be placed in the sidewalk are subject to applicable street right-of-way by-laws. The following documents must also be consulted:

- City of Toronto Accessibility Design Guidelines
- City of Toronto Draft Streetscape Manual
- City of Toronto Vibrant Streets Guidelines



Criteria for the location of street furniture have been developed by Toronto's coordinated street furniture program and listed in the Vibrant Streets Guidelines. All street furniture in the public right-of-way, including bicycle racks, must be placed in such a way as to satisfy these criteria:

- Establish and maintain a distinct, linear pedestrian clearway
- Furniture size to be responsive to width of pedestrian clearway
- Quantity of furnishings to reflect the use patterns and placement opportunities
- Sidewalks and street furniture to be accessible to all users
- Maintain sight lines at intersections
- Respond to surrounding architecture and open space
- Respond to specific site conditions



Proposed bicycle locker design from Toronto's coordinated street furniture program.

In some instances, a property owner may wish to place their own bicycle parking racks in the public right-of-way. In this case a property owner must enter into an encroachment agreement with the City. The encroachment agreement will include approval for both the design and the placement of the bicycle racks.

### 5.3 LONG-TERM PARKING

Long-term parking is not often placed in the public right-of-way. In most cases the guidelines for the placement and design of street furniture would not allow bicycle cages or bike lockers to be placed on the sidewalk. However, for areas where it has been deemed appropriate, Toronto's new coordinated street furniture project, is developing a design for bicycle lockers that will be consistent with other street furniture elements.



Bicycle parking is one of the six "spokes" of the Toronto Bike Plan.

## 6. POLICY CONTEXT

There are a number of existing City policies that support the development of high quality bicycle parking infrastructure as a means to encourage a reduction in auto dependency, promote a standard of "green" development and support bicycle use city-wide.

### 6.1 CITY OF TORONTO OFFICIAL PLAN

The City's Official Plan supports increased bicycle use through a number of policies. Among these policies are specific provisions for bicycle parking as well as the reduction of auto dependency in new developments. Please see Appendix B for a list of the key Official Plan policies related to these Guidelines.

### 6.2 CITY OF TORONTO BIKE PLAN

The Toronto Bike Plan establishes a vision for cycling in Toronto that is reflected in the general policies of the Official Plan. It provides integrated principles, objectives and recommendations regarding bicycle related programming and infrastructure. The Plan recommends "That the City produce bicycle parking guidelines for developers and property managers to assist in the provision of high quality bicycle parking facilities." (Recommendation 9-5 <http://www.toronto.ca/cycling/bikeplan/>).

As part of the Bike Plan study, a comprehensive public attitude survey conducted in 1999 asked recreational cyclists what improvements would encourage them to use their bicycles to travel to work or school. Survey results showed approximately 49,000 cyclists in Toronto consider secure bicycle parking as their second most important need, second only to more bike lanes. Data also showed that approximately 33,000 Toronto cyclists identify access to shower and change facilities as an important feature to encourage regular bicycle commuting.

### 6.3 TORONTO GREEN DEVELOPMENT STANDARD 2008

The Toronto Green Development Standard implements the policies of the Official Plan through a set of performance targets that encourage sustainable site and building



design. The targets respond directly to Toronto's local environmental pressures, integrating existing City policies, programs, guidelines and targets with appropriate standards from private rating systems such as Leadership in Energy and Environmental Design (LEED) and Green Globes.

During the development approval process for all applications involving Official Plan and zoning amendments, site plan approval and plans of subdivision, a green development checklist is completed by the applicant to summarize the minimum and enhanced green features included in their proposal.

The 2008 Toronto Green Development Standard for Mid- to High-Rise Residences, Commercial, Industrial and Institutional Development contains minimum targets for bicycle parking as follows:

- Provide at least 1.0 bicycle spaces per unit for residential buildings with more than 10 units in the downtown area and 0.75 bicycle spaces per unit in residential buildings with more than 10 units outside of the downtown area.
- Provide 10% of long-term parking at grade in a convenient secure location
- Provide 1 parking space for every 15 regular building occupants (Minimum of one space required).
- Provide shower and change facilities for workplaces (One facility for each gender for every 30 bicycle parking spaces).
- Provide signage and road markings for cyclists on large sites.

<http://www.toronto.ca/environment/greendevlopment.htm>

## **6.4 CITY OF TORONTO ZONING BY-LAW PROJECT**

Toronto's Zoning By-Law Project began in 2003. For this project the 41 zoning by-laws inherited from the municipalities following amalgamation are being "harmonized" into one comprehensive Zoning By-Law. Up until the completion of the Zoning By-law Project, the bicycle parking by-laws that are currently in place in the former municipalities are in effect. This includes Zoning By-Law No.438-86; North York Centre Secondary Plan's density incentives for below-grade bicycle storage, and



Short-term and long-term bicycle parking options at Toronto City Hall.



Toronto Bike Week group commute.

Zoning By-Law No.104-2008 in the Scarborough District. As part of the Zoning By-law project two consultant studies have been completed to develop recommendations for new bicycle parking standards for selected land uses. Currently, City staff are reviewing these consultant studies and the existing bicycle parking standards in Toronto with a view to developing one city-wide standard for bicycle parking. Please see Appendix B for more detailed information on current district standards and proposed city-wide bicycle parking requirements.

### **6.5 VIBRANT STREETS GUIDELINES**

The Vibrant Streets document provides street furniture design and policy guidelines that were developed for Toronto's coordinated street furniture program. With a view to harmonizing the design, scale, materials and placement of street furniture in Toronto, Vibrant Streets will condition the design and placement of all street furniture including bicycle parking racks in the public right-of-way (on the sidewalk).

[http://www.toronto.ca/involved/projects/streetfurniture/pdf/vibrant\\_streets.pdf](http://www.toronto.ca/involved/projects/streetfurniture/pdf/vibrant_streets.pdf)

### **6.6 NATIONAL AND INTERNATIONAL ENVIRONMENTAL STANDARDS AND CERTIFICATIONS**

Various nationally and internationally recognized sustainable design standards incorporate bicycle parking as a component of environmentally responsible design. These standards include:

- *Leadership in Energy and Environmental Design (LEED)*

The popular LEED Green Building Rating system was developed initially by the US Green Building Council and then adapted by the Canadian Green Building Council to administer in Canada. The program provides a rating system for high performance green buildings by rewarding points for including various features of sustainable design, up to a total of 70 possible points. One point is earned by meeting Sustainable Sites (SS) Credit 4.2: Alternative Transportation – Bicycle Storage and Changing Rooms which requires the provision of bicycle storage, changing rooms and shower facilities.



Humber river pedestrian and bicycle bridge



- *Green Globes Design for New Buildings and Retrofits:*

Green Globes provides an online assessment protocol, rating system and guidance for green building design, operation and management. It provides market recognition of a building's environmental attributes through third-party verification.

Under Section C.5 – Energy Efficient Transportation, Green Globes awards points for the provision of bicycle storage areas and change rooms with the intent to reduce fossil fuel consumption for commuting (<http://www.greenglobes.com/design/criteria.asp>).

- *Promoting Sustainable Transportation Through Site Design: an ITE Proposed Recommended Practice (Canadian Institute of Transportation Engineers):*

The purpose of these site design guidelines is to guide the planning and review of non-residential developments so that sites are designed to be more accessible to travel modes other than single-occupant vehicles. Guidelines for bicycle parking supply, location and access are provided as a component of site design. (Section 3.4.7 Bicycle Parking) [http://www.cite7.org/Technical\\_Projects/sitesdesignreview.htm](http://www.cite7.org/Technical_Projects/sitesdesignreview.htm)



City of Toronto's Bikeway Network signage on Royal York road.

## 6.7 PROVINCIAL POLICIES

Places to Grow: Growth Plan for the Greater Golden Horseshoe

The Growth Plan for the Greater Golden Horseshoe is a framework for implementing the Ontario Government's vision to build stronger, prosperous communities by managing growth in this region. The Plan was prepared under the Places to Grow Act, 2005 and sets out policies to provide leadership for improving present and future growth to 2031. The Plan guides decision-making on a wide range of issues including transportation, land-use planning infrastructure planning, urban form, housing, natural heritage and resource protection. Plan policies support the vision of an integrated regional transportation system that will include bicycle transportation as a practical element.

<http://www.placestogrow.ca/>



## 7. CONCLUSION:

Bicycle use plays an important role in the development of a more efficient transportation system in Toronto. The fear of vandalism and theft can be a significant deterrent to regular bicycle use. Providing high quality, secure bicycle parking infrastructure and bicycle-friendly policies in new and existing developments will go a long way to support and increase the use of bicycles for every day travel needs. High quality bicycle parking must be incorporated into overall site design from the start. Last minute efforts to meet parking requirements and fill in unallocated spaces will not produce a well-designed facility. Although aimed at new developments, the Bicycle Parking Guidelines can also be applied to existing developments looking to improve bicycle parking facilities. Working together, architects, developers, urban designers, planners, building owners and managers can provide a vital contribution to a sustainable transportation system and support a growing culture of active transport in Toronto.







## 9. APPENDIX B: RELEVANT POLICIES AND BY-LAWS

### CITY OF TORONTO OFFICIAL PLAN

The following Official Plan policies provide specific provisions for bicycle parking as well as the reduction of auto dependency in new developments.

#### **Section 2.4 Bringing the City Together: A Progressive Agenda of Transportation Change**

##### *Policy #7:*

Policies, programs and infrastructure will be introduced to create a safe, comfortable and bicycle friendly environment that encourages people of all ages to cycle for everyday transportation and enjoyment including:

- a) *an expanded bikeway network;*
- b) *provision of bicycle parking facilities in new developments;*
- c) *provision of adequate and secure bicycle parking at rapid transit stations; and*
- d) *measures to improve the safety of cyclists through the design and operation of streets and through education and promotion programs.*

##### *Policy #3:*

*In targeted growth areas, planning for new development will be undertaken in the context of reducing auto dependency and the transportation demands and impacts of such new development assessed in terms of the broader social and environmental objectives of the Plan's reurbanization strategy.*

In other words, planning for new development will include measures to reduce auto dependency with each development site as well as measures to achieve a mixed use pattern of development in targeted growth areas...ect. These efforts will increase the opportunity for better walking and cycling conditions and minimize long term needs for costly transportation infrastructure as well as costs associated with social, environmental and health effects of increased auto use.



## Section 4.2 Apartment Neighbourhoods

Policy #2 (d):

*Development in Apartment Neighbourhoods will contribute to the quality of life by including sufficient off-street motor vehicle and bicycle parking for residents and visitors;*

While this policy is covered in the Zoning By-Law, important issues concerning the quality and practicability of bicycle parking infrastructure will determine...ect the suitability of these facilities to promote increased bicycle use. Sections 2-4 of the Bicycle Parking Guidelines address these issues in detail.

For more information on Toronto's Official Plan: [http://www.toronto.ca/planning/official\\_plan/introduction.htm](http://www.toronto.ca/planning/official_plan/introduction.htm)

### BICYCLE PARKING REQUIREMENTS IN THE SOUTH DISTRICT

Buildings erected in the South District (the former City of Toronto) after July 20, 1993 need to comply with the specific bicycle parking and shower-change facility requirements listed below.

By-law 438-86, Section 4 (13) Bicycle parking spaces and shower - change facilities: when required, number, location and type

*(a) Subject to paragraphs (b), (c) and (d), no person shall erect or use a building or structure in any use district for a purpose listed below unless bicycle parking spaces and/or shower - change facilities are provided and*

*maintained, on the same lot as the building, at least to the extent prescribed in the following table:*

*(b) The requirements of paragraph (a) shall not apply to any floor space used on or before July 20, 1993.*

*(c) The bicycle parking spaces required by paragraph (a) shall be provided in the following proportion: 80 percent as bicycle parking space - occupant and 20 percent as bicycle parking spaces - visitor. (1997-0422)*

*(d) Not more than 50 per cent of bicycle parking spaces - occupant shall be provided in a manner that requires a person to park the bicycle in a vertical position.*

*(e) Bicycle parking spaces required by paragraph (a) shall not be provided within a dwelling unit or a balcony thereof nor within commercial suites.*

### Section 2 - Definitions and interpretation, Zoning By-law No. 438-86 (summarized)

"bicycle parking space"

means a bicycle parking space - occupant or a bicycle parking space - visitor;

"bicycle parking space - visitor"

may be located outdoors or indoors but not within a secured room, enclosure or bicycle locker;

"bicycle parking space - occupant"

may be a bicycle rack or bicycle locker. In the case of a bicycle rack it must be located in a secured room or area;

USE	REQUIREMENT
<b>Residential:</b> Dwelling units in a building containing 10 or more dwelling units, other than senior citizens' housing:	0.75 bicycle parking spaces for each dwelling unit, or a fraction thereof equal to or greater than 0.5, to a maximum of 200 bicycle parking spaces;
<b>Non-residential:</b> uses listed in sections 8(1)(f)(b)(iv), (v) and (vi), in a building located in any use district and where the combined non-residential gross floor area used for those purposes is equal to or greater than 2,000 square metres:	6 bicycle parking spaces, or one bicycle parking space for every 1,250 square metres of net floor area or fraction thereof equal to or greater than 0.5, whichever is greater
<b>Non-residential:</b> uses listed in sections 8(1)(f)(b)(iv), (v) and (vi), in a building located in any use district and where the combined non-residential gross floor area used for those purposes is equal to or greater than 20,000 square metres:	1 shower-change facility for each gender or greater than 20,000 square metres:



**"bicycle parking space"**

means an area that is equipped with a bicycle rack for the purpose of parking and securing bicycles, and:

- i. where the bicycles are to be parked on a horizontal surface, has horizontal dimensions of at least 0.6 metres by 1.8 metres and a vertical dimension of at least 1.9 metres;
- ii. where the bicycles are to be parked in a vertical position, has horizontal dimensions of at least 0.6 metres by 1.2 metres and a vertical dimension of at least 1.9 metres.

**NORTH YORK CENTRE SECONDARY PLAN**

In December 2007 Toronto City Council adopted an amendment to the North York Centre Secondary Plan respecting below-grade bicycle storage. The amendment will be presented as a settlement at the Ontario Municipal Board in 2008. The policy requires the provision of at-grade bicycle parking in all major new developments in the North York Centre and reads as follows:

**Definition, Number, Location and Dimensions:**

A bicycle parking space is an area designed and equipped exclusively for the purpose of parking and securing a bicycle. The space will not be provided within a dwelling unit, balcony or commercial suite. All types of bicycle parking space arrangements (e.g. racks, lockers, etc) can be considered in the review of meeting these guidelines. The minimum number of bicycle parking spaces identified in this policy are to be provided in an at-grade common bicycle room conveniently accessible to the outside. Additional bicycle parking spaces may be provided in other locations

***Dimensions of bicycle parking spaces:***

Minimum 1.9 m high by 0.6 m wide by 1.2 metres deep (vertical parking) or 1.8 metres deep (horizontal parking). No more than 50% of spaces will be provided as vertical parking. Dimensions of shower-change facilities will meet the minimum requirements of the Ontario Building Code.

***Number of Bicycle Parking Spaces for Commercial Uses (Office, Institutional, Ancillary Retail and Service***

***Commercial):***

Minimum: Greater of 1 space / 2,000 m<sup>2</sup> or 4 spaces for projects with GFA >2,000 m<sup>2</sup>  
Maximum: None 1 shower-change facility for each gender for projects with GFA >20,000 m<sup>2</sup>.

***Number of Bicycle Parking Spaces for Residential Uses***

Minimum: 0.10 spaces / unit for projects with 40 or more non grade-related dwelling units  
Maximum: None No shower-change facility required

***Other Uses***

Proponents of development containing uses not covered above will identify bicycle parking standards for such uses that are consistent with the context and guidelines noted above.

**BICYCLE PARKING REQUIREMENTS IN SCARBOROUGH DISTRICT:**

Adoption of Official Plan Amendment No. 42 & Zoning By-Law No. 104-2008:

The Zoning By-Law implementing the Danforth Avenue Study (from Victoria Park Avenue eastwards to Medford Avenue, east of Warden Avenue) includes specific bicycle parking requirements for residential developments in the area. Residential developments are required to provide 0.5 bicycle parking spaces per dwelling unit of which 80% is long-term parking for occupant use and 20% is short-term parking for visitors. [http://www.toronto.ca/planning/pdf/danfoth\\_notice\\_adoption\\_feb08.pdf](http://www.toronto.ca/planning/pdf/danfoth_notice_adoption_feb08.pdf)

**PRELIMINARY DIRECTIONS FOR A NEW ZONING BY-LAW**

As part of Toronto's Zoning By-law project two consultant studies have been completed to develop new parking standards for selected land uses. As a result of these studies the following city-wide bicycle parking standards have been proposed by the consultants. These standards are currently under review by City staff.

In addition, the proposed standard also recommends that clothing lockers be supplied at a total of 0.7 times the number of Type 1 bicycle parking spaces.

<http://www.toronto.ca/zoning/>



**Proposed Minimum Number of Required Off-Street Bicycle Spaces\*\***

USE	Downtown and Central Waterfront / City Centres †		Rest of the City	
	TYPE 1*	TYPE 2*	TYPE 1*	TYPE 2*
<b>General Office/ Government Office</b>	0.2 spaces/ 100m2	Greater of: 0.2 spaces/ 100m2 or 6 spaces for sites with non-residential GFA>1000m2	0.13 spaces/ 100m2	Greater of: 0.15 spaces/ 100m2 or 6 spaces for sites with non-residential GFA>1000m2
<b>Medical Office</b>	0.15 spaces/ 100m2	Greater of: 0.15 spaces/ 100m2 or 6 spaces for sites with non-residential GFA>1000m2	0.1 spaces/ 100m2	Greater of: 0.1 spaces/ 100m2 or 6 spaces for sites with non-residential GFA>1000m2
<b>Retail/ Restaurant</b>	0.2 spaces/ 100m2	Greater of: 0.3 spaces/ 100m2 or 6 spaces for sites with non-residential GFA>1000m2	0.13 spaces/ 100m2	Greater of: 0.25 spaces/ 100m2 or 6 spaces for sites with non-residential GFA>1000m2
<b>Multi-Use Residential</b>	80% of 1.0 spaces / unit	20% of 1.0 spaces per unit	80% of 0.75 spaces per unit	20% of 0.75 spaces per unit

† Toronto Official Plan -Map 2. \* Type 1 = Long-term parking; Type 2 = Short-term parking. \*\* no upper limit on bike parking spaces

**Proposed minimum number of shower facilities required for each gender (for commercial uses)**

Required Number of Type 1 Bicycle Parking Spaces	Number of Shower Stalls
0-4	0
0-29	1
30-59	2
60-89	3
90-119	4
120-149	5
150-179	6
Over179	7 plus 1 for additional 30 bicycle spaces



## 10. APPENDIX C: BICYCLE PARKING BROCHURE

In 2003 the City of Toronto produced a bicycle parking brochure: *Bicycle Parking: A Guide for Business Owners and Cyclists in the City of Toronto*. This brochure includes information on bicycle parking options, tips for cyclists on avoiding bicycle theft, and the benefits of bicycle commuting.

For more information: [http://www.toronto.ca/bug/pdf/bicycle\\_parking\\_guide.pdf](http://www.toronto.ca/bug/pdf/bicycle_parking_guide.pdf)

